

# **ROTOVAC**



## ***WIDE-TRACK Extraction System Owner's Manual***

WT/11/28/2007

---

## OVERVIEW

The Rotovac **WIDE-TRACK** is the largest and most advanced Rotary Jet Extraction machine ever developed.

A 24" wide cleaning path in conjunction with patented rotary extraction cleaning heads produce high speed cleaning results while greatly reducing operator fatigue.

## OPERATOR'S RESPONSIBILITY

As with all equipment, proper operation and maintenance play a vital role in the performance of the **WIDE-TRACK**. It is therefore extremely important that this Owner's Manual is read and understood before operating your **WIDE-TRACK**.

## CALL BEFORE USING FOR THE FIRST TIME !

If you are using the **WIDE-TRACK** for the first time, read this owners manual and then call Rotovac toll-free for valuable tips and pointers at **1-888-768-6822**.

**(8:00 a.m. to 5:00 p.m. Monday through Friday P.S.T.)**



PST



ROCK MT.



CENTRAL



EASTERN

---

## ROTOVAC **WIDE-TRACK** OPERATION

The on/off push button switch is located on the top of the control box on the upper handle. The speed control dial is located on the front of the control box. This allows adjusting the head speed rpm for different conditions. The solution valve trigger is located under the right handle grip. The red lever solution flow control valve allows for the adjustment of flow rate.

## CLEANING TECHNIQUE

With the solution flow control valve open and the solution trigger activated, make cleaning passes in a forward and back motion. Overlap your cleaning passes to cover the gap between the two heads. The more soiled the carpet, the slower you should make the cleaning passes. After the cleaning step, let off the solution valve trigger and go back over the area with a vacuum only "dry pass" to provide maximum extraction for faster drying. For normal carpet cleaning we recommend operating spray pressure between 100 and 300 PSI. For hard surface cleaning the pressure can be adjusted anywhere from 100 to 1000 PSI.

## WHEEL ADJUSTMENT

The front and the rear wheels are adjustable to allow the **WIDE-TRACK** to clean all types of carpet from plush installed over pad to direct glue down commercial carpet. When adjusting the wheels, your goal is to have the cleaning heads running parallel (flat) with the floor (not nose up or nose down) with just the right amount of weight on the heads so that it pushes easily and also agitates and vacuums the carpet efficiently. It is very important that the wheels are in proper adjustment for maximum cleaning performance. The vacuum shoes must maintain contact with the carpet or it will not clean or extract well. When cleaning installed over pad carpeting with a powerful truckmount system you can sometimes adjust the wheels down so that the vacuum shoes are suspended slightly above the carpet. When the strong vacuum is then turned on, the carpet will actually be sucked up to the heads creating a wave like effect in the carpet for maximum air flow rather than the heads sucking down to the floor.

---

## SPEED CONTROL DIAL

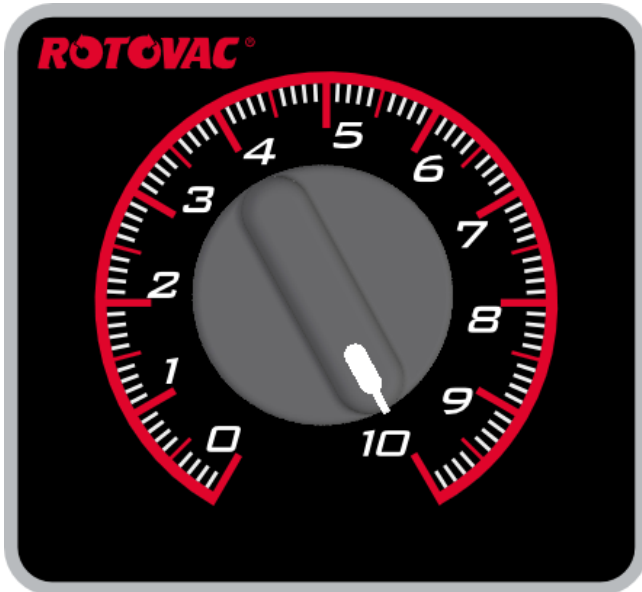

The head rotation speed is adjustable from low to high speed (up to 200 RPM). This allows the operator to customize the head speed for different types of carpets. When cleaning berber or commercial glue down, a slower speed will sometimes give better cleaning and/or drying results. Experiment for best performance.

Examples of when you may want to use slower speed 1) Not handling properly, chattering or jumping on hard glue down carpet 2) Cleaning close to an object you don't want heads to impact such as, where the tile floor meets the carpet, floor heat registers, metal thresholds, furniture legs or anything else you don't want the rotary heads to impact. 3) Dry pass on carpet that is difficult to dry such as Berber, 4) Hard surface cleaning.

## PRECAUTIONS

Be careful not allow the rotating vacuum heads to run into any stationary objects such as **metal thresholds, floor vent registers, furniture legs etc.** Slow down the head speed when cleaning close to any object the vacuum shoes may hit.

## TRANSPORTING

---

Be careful that the **WIDE-TRACK** cleaning heads do not come loose, unscrew and fall off while you are carrying or rolling it around.

Before carrying or rolling make sure the heads are screwed on tight.

## WARNINGS-

\*Do not use **WIDE-TRACK** in standing water, such as on a flooded carpet.

\*Always use a grounded electrical outlet. Keep the control box on the handle dry. If the control box becomes wet, do not operate, call Rotovac for instructions.

\*Always wear rubber-soled shoes when operating the **WIDE-TRACK**.

\*Only trained personnel who have read this manual and understand completely the information herein should operate the **WIDE-TRACK**.

\* Regularly inspect the cleaning heads for any nicks or burrs. Grind or sandpaper away any sharp edges, nicks or burrs before use.

\* Maintain tightness of all screws at all times.

## ROUTINE MAINTENANCE

### Daily:

**Vacuum Heads:** remove and clean.

**Vacuum Hoses:** inspect / repair clogged debris or breaks.

**Felt Seals:** inspect / replace both after 500 to 600 hours of use.

**General:** inspect / repair loose fasteners. Replace faulty or badly worn components.

---

## Other:

- Carbon Brushes:** (located on the side of the housing, front and back) replace two per motor after 1000 to 1200 hours of use.
- Power Cord:** inspect / repair cuts and breaks.

## REMOVING THE CLEANING HEAD

To familiarize yourself with the **WIDE-TRACK** the first thing to learn is how to remove and replace the rotary cleaning head assemblies for maintenance and cleaning. This is the single most important procedure of regular maintenance.

## IMPORTANT!!

Remove the cleaning heads by unscrewing them **in the same direction that they rotate during operation**. Tap on the back side of the steel vacuum shoe (not the side with the spray jet) with a rubber mallet to loosen the head. Now it will spin off for cleaning or adjustment.

**Note:** When replacing the cleaning head always make sure that the vacuum is disconnected or turned off so the felt seal remains seated in position on the 6 small studs when replacing the cleaning head. If the vacuum is running when replacing the cleaning head, the felt seal will suck up off of the studs and get chewed up.

## FELT VACUUM SEALS

Check the felt vacuum seals on the vacuum head for damage or wear. **A GOOD FELT SEAL IS IMPORTANT FOR MAXIMUM VACUUM EXTRACTION PERFORMANCE**. An excessively worn or torn felt seal will result in more water left in the carpet than is desirable. The felt seal will perform better and last longer if treated with a non-oily silicone spray. We prefer Dupont Silicone/Teflon spray.

---

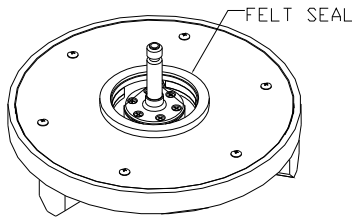

**Carpet and hard floor head**

## VACUUM SYSTEM MAINTENANCE

To replace worn or damaged Vacuum Shoes, first remove the Head from the machine (see previous). The cover can then be removed by removing the 6 screws holding it in place. This allows access to the vacuum channels and ports for cleaning. It also allows access to the screws holding the vacuum shoes in place. If the shoes are being changed, remove the screws, and reattach new shoes. Tighten screws down securely. Assure that the seal retainers are returned to their original position. When reinstalling the cover assembly, **make sure that the vacuum channels in the cover/seal match up with the channels in the molded head**, and retighten. The Round Glide Discs are accessible from the underside without disassembly.

## SPRAYER SYSTEM MAINTENANCE

Periodically tilt the **WIDE-TRACK** back and visually inspect the spray pattern of the jets to make sure they are not clogged or aimed in the wrong direction. The spray fan pattern should be aligned with the vacuum slots and should never go beyond the outer edge of the vacuum slot.

---

## CARPET CLEANING HEADS

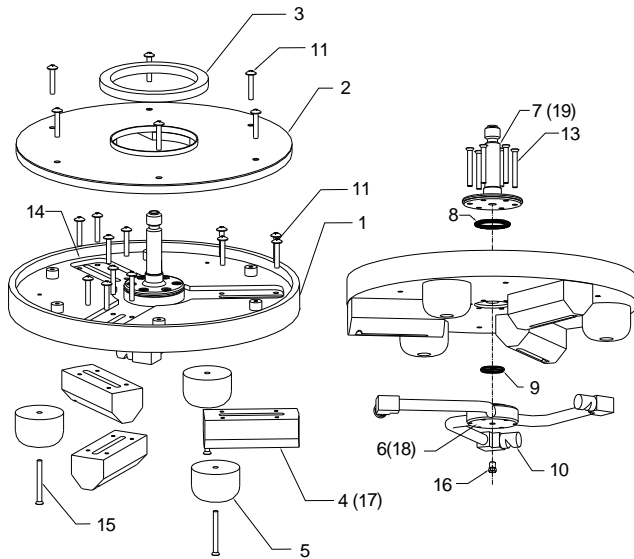

### Vacuum System Maintenance

### Sprayer System Maintenance

ITEM #	QUANTITY	ROTOVAC P/N	DESCRIPTION
1	1	RP-203	VACUUM DISC
2	1	RA-106	COVER/SEAL ASSEMBLY
3	1	S-027	FELT SEAL
4	3	RA-113	SMOOTHGLIDE VACUUM SHOE ASSEMBLY L.H.
5	3	RP-207	ROUND GLIDE DISC
6	1	RA-108	SPRAYER ASSEMBLY L.H.
7	1	A-2329AL	MALE SHAFT (LH)
8	1	RV-412	SMALL O-RING
9	1	S-023	O-RING
10	3	S-026	SPRAY JET
11	18	RV-401	ROUND HEAD SCREW
13	6	RV-402	FLAT HEAD SCREW
14	3	RP-224	GASKET RETAINER (NOT SHOWN THIS VIEW-SEE NEXT)
15	3	RV-439	FLAT HEAD SCREW
16	1	RA-116	VENT CHECK (FROM S/N 1803)
17	1	RA-131	SMOOTHGLIDE VACUUM SHOE ASSEMBLY R.H.
18	1	RA-134	SPRAYER ASSEMBLY R.H.
19	1	A-2329AR	MALE SHAFT (RH)
20	1	RA-105	L.H. CARPET HEAD ASSY
21	1	RA-134	R.H. CARPET HEAD ASSY



## TROUBLE SHOOTING GUIDE

### 1. Difficult to push / Motor bogging down

\*The **WIDE-TRACK** has a built in torque governor that will cause the motor to bog down or stop if overloaded or used improperly. This feature ensures long motor and gear box life because it forces the operator to use the **WIDE-TRACK** correctly and not abuse the machine during operation. When operated correctly, the torque governor will put out plenty of power to do the job while also protecting the motor gear box from premature wear.

\***NOTE:** If you are using a truck mounted vacuum system and the unit is bogging down, adjust the wheels downward to take some weight off of the vacuum shoes. For installed over pad carpet the wheels can be adjusted so that the vacuum shoes are suspended slightly above the carpet. When the strong vacuum is then turned on, the carpet will actually suck up to the heads creating a wave like effect in the carpet for maximum air flow rather than sucking down to the floor.

### 2. Motor running Hot.

\*The **WIDE-TRACK** drive motor is made to safely run at temperatures up to 160° F. Note that metal surfaces at 120° F can be comfortably handled for only several seconds.

### 3. Overspray from cleaning head, slinging water.

\*Make sure spray jets are pointing slightly inward and your psi is not turned up too high. Recommend 100 to 300 psi

\*Turn down the motor speed rpm.

### 4. Leaving carpet too wet.

\*Make sure felt vacuum seal is not worn or torn.

\*Turn down psi.

\*Make slower vacuum only dry pass.

\*Turn down motor speed during dry pass.

\*Check to make sure your vacuum system is working properly and the filters in your extractor are not clogged with carpet lint.

\*Assure heads are not clogged with dog hair, etc.

### 5. Other problems

\*Call our service department toll free 888-768-6822

---

## **WARRANTY**

Rotovac Corporation products are warranted to be free of defects in material for 1 year as noted below:

During this warranty period, we will repair or replace, at our sole option, free of charge, any parts shown to be defective in either material or workmanship. Said parts must be returned with postage or freight pre-paid. Specific parts, such as switches, vacuum motors, pumps, fittings, etc., are also warranted for a period of 1 year from date of original purchase.

This warranty is for replacement of defective parts or workmanship only. **IT DOES NOT PROVIDE FOR REPLACEMENT OF COMPLETE UNITS DUE TO DEFECTIVE PARTS.** It does NOT cover normal wear items such as hoses, power cords, bumpers, carbon brushes, gaskets, etc., which require replacement as a result of ordinary usage. Also, failures caused by abuse, neglect, alterations or operation contrary to manufacturer's recommendations are not warranted.

Replacement parts are warranted only for the remainder of the original warranty period.

This warranty does not cover labor or other charges in connection with replacement parts. **NO LOCAL SERVICE OR REPAIR CHARGES ARE ALLOWED UNLESS PRIOR AUTHORIZATION IS OBTAINED.**

There are no other warranties, expressed or implied, made with respect to this equipment. The manufacturer assumes no responsibility for damages resulting from the use or misuse of this equipment.

## **Rotovac Corporation**

17905 Bothell Everett Hwy  
Mill Creek, Washington 98012  
Ph. (425) 883-6746 Fax (425) 883-8953  
<http://www.Rotovac.com>