

Stormchaser™

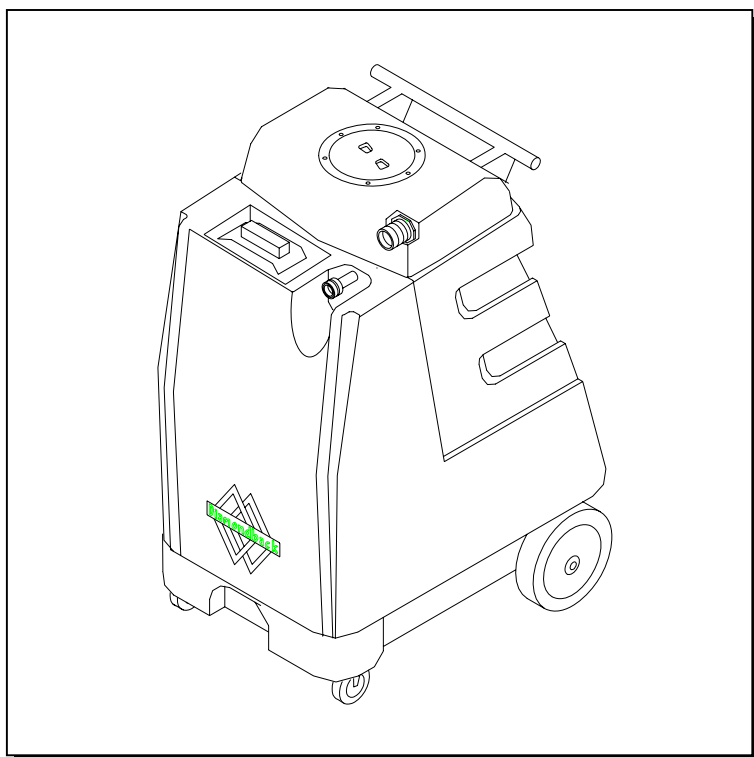

PORTABLE EXTRACTOR



Operating Instructions

MODELS: 900-01
10070480
900-04
10070500

Read these instructions before using the machine

P

86038660 03/29/07

PRV NO. 98844

MACHINE DATA LOG/OVERVIEW

MODEL	_____
DATE OF PURCHASE	_____
SERIAL NUMBER	_____
SALES REPRESENTATIVE #	_____
DEALER NAME	_____
OPERATIONS GUIDE NUMBER	_____
PUBLISHED	_____

YOUR DEALER	
Name:	_____
Address:	_____
Phone Number:	_____

OVERVIEW

The Stormchaser is an electric powered carpet extractor intended for commercial use. This appliance applies a cleaning solution to the carpet and then vacuums the soiled water back into the recovery tank.

TABLE OF CONTENTS

<i>Machine Data Log/Overview</i>	2
<i>Table of Contents</i>	3

HOW TO USE THIS MANUAL

<i>How to use this Manual</i>	1-1
-------------------------------------	-----

SAFETY

<i>Important Safety Instructions</i>	2-1
<i>Hazard Intensity Level</i>	2-2
<i>Safety Label Location</i>	2-3
<i>Grounding Instructions</i>	2-4

OPERATIONS

<i>Technical Specifications</i>	3-1
<i>Controls</i>	3-2
<i>Machine Operation</i>	3-3
<i>Pre-Run Machine Inspection</i>	3-3
<i>Equipment Set-Up</i>	3-3
<i>Priming the Pump</i>	3-3
<i>Emptying & Cleaning Tanks</i>	3-4
<i>Shut Down and Storage</i>	3-4

MAINTENANCE

<i>Daily Maintenance</i>	4-1
<i>Periodic Maintenance</i>	4-1
<i>Monthly Maintenance</i>	4-1
<i>Semi-annually</i>	4-1
<i>Lubrication</i>	4-1
<i>Storage</i>	4-1
<i>Solution Pump Replacement</i>	4-2
<i>Vacuum Motor Replacement</i>	4-2
<i>Pump Replacement Kits</i>	4-3
<i>Pressure Regulator</i>	4-4
<i>Machine Troubleshooting</i>	4-5

GROUP PARTS LIST

<i>Control Panel Group</i>	5-1
<i>Frame Group (100 psi)</i>	5-3
<i>Frame Group (200 psi)</i>	5-5
<i>Pump Group (100 psi)</i>	5-7
<i>Pump Group (200 psi)</i>	5-9
<i>Recovery Tank Group</i>	5-11
<i>Vacuum Motor Group (Upper)</i>	5-13
<i>Vacuum Motor Group (Lower)</i>	5-15
<i>Wiring Diagram (100 psi)</i>	5-17
<i>Wiring Diagram (200 psi)</i>	5-18
<i>Suggested Spare Parts</i>	5-19
<i>Notes</i>	5-20
<i>Warranty</i>	5-21

HOW TO USE THIS MANUAL

This manual contains the following sections:

- HOW TO USE THIS MANUAL
- SAFETY
- OPERATIONS
- MAINTENANCE
- PARTS LIST

The HOW TO USE THIS MANUAL section will tell you how to find important information for ordering correct repair parts.

Parts may be ordered from authorized dealers. When placing an order for parts, the machine model and machine serial number are important. Refer to the MACHINE DATA box which is filled out during the installation of your machine. The MACHINE DATA box is located on the inside of the front cover of this manual.

MODEL _____
DATE OF PURCHASE _____
SERIAL NUMBER _____
SALES REPRESENTATIVE # _____
DEALER NAME _____
OPERATIONS GUIDE NUMBER _____
PUBLISHED _____

The model and serial number of your machine is on the inside of the control panel.

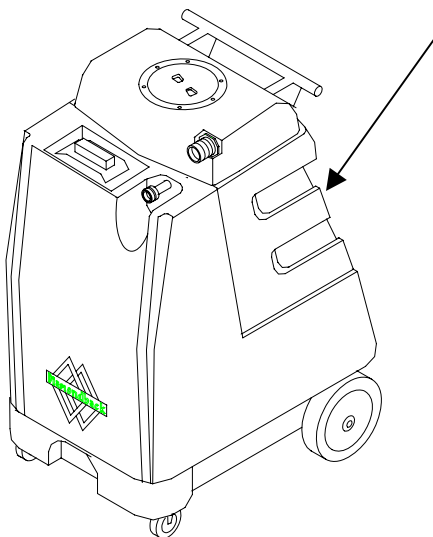

The SAFETY section contains important information regarding hazard or unsafe practices of the machine. Levels of hazards is identified that could result in product or personal injury, or severe injury resulting in death.

The OPERATIONS section is to familiarize the operator with the operation and function of the machine.

The MAINTENANCE section contains preventive maintenance to keep the machine and its components in good working condition. They are listed in this general order:

- Service Schedule
- Lubrication
- Storage
- Vacuum Motor Replacement
- Solution Pump Replacement
- Pump Kits
- Pressure Regulator (200PSI model only)
- Troubleshooting

The PARTS LIST section contains assembled parts illustrations and corresponding parts list. The parts lists include a number of columns of information:

- **REF** – column refers to the reference number on the parts illustration.
- **PART NO.** – column lists the part number for the part.
- **PRV NO.** – reference number.
- **QTY** – column lists the quantity of the part used in that area of the machine.
- **DESCRIPTION** – column is a brief description of the part.
- **SERIAL NO. FROM** – column indicates the first machine the part number is applicable to. When the machine design has changed, this column will indicate serial number of applicable machine. The main illustration shows the most current design of the machine. The boxed illustrations show older designs. If column has an asterisk (*), call manufacturer for serial number.
- **NOTES** – column for information not noted by the other columns.

NOTE: If a service or option kit is installed on your machine, be sure to keep the KIT INSTRUCTIONS which came with the kit. It contains replacement parts numbers needed for ordering future parts.

IMPORTANT SAFETY INSTRUCTIONS

When using an electrical appliance, basic precaution must always be followed, including the following:

READ ALL INSTRUCTIONS BEFORE USING THIS MACHINE.

This machine is for commercial use.



WARNING:

To reduce the risk of fire, electric shock, or injury:

Connect to a **properly grounded outlet**. See Grounding Instructions.

Do not leave the machine unattended. Unplug machine from outlet when not in use and before maintenance or service.

Use only indoors. Do not use outdoors or expose to rain.

Do not allow machine to be used as a toy. **Close attention** is necessary when used by or near children.

Use only as described in this manual. Use only manufacturer's recommended components and attachments.

Do not use damaged electrical cord or plug. Follow all instructions in this manual concerning grounding the machine. If the machine is **not working properly**, has been dropped, damaged, left outdoors, or dropped into water, return it to an authorized service center.

Do not pull or carry machine by electrical cord, use as a handle, close a door on cord, or pull cord around sharp edges or corners.

Do not run machine over cord. **Keep** cord away from heated surfaces.

Do not unplug machine by pulling on cord. To unplug, grasp the electrical plug, not the electrical cord.

Do not handle the electrical plug or machine with wet hands.

Do not operate the machine with any openings blocked. Keep openings free of debris that may reduce airflow.

This machine is intended for cleaning carpet only.

Do not vacuum anything that is burning or smoking, such as cigarettes, matches, or hot ashes.

This machine is not suitable for picking up health endangering dust.

Turn off all controls before unplugging.

Machine can cause a fire when operating near flammable vapors or materials. Do not operate this machine near flammable fluids, dust or vapors.

This machine is suitable for commercial use, for example in hotels, schools, hospitals, factories, shops and offices for more than normal housekeeping purposes.

Maintenance and repairs must be done by qualified personnel.

If foam or liquid comes out of machine, switch off immediately.

SAVE THESE INSTRUCTIONS

HAZARD INTENSITY LEVEL

The following symbols are used throughout this guide as indicated in their descriptions:

HAZARD INTENSITY LEVEL

There are three levels of hazard intensity identified by signal words -**WARNING** and **CAUTION** and **FOR SAFETY**. The level of hazard intensity is determined by the following definitions:

⚠ WARNING

WARNING - Hazards or unsafe practices which COULD result in severe personal injury or death.

⚠ CAUTION

CAUTION - Hazards or unsafe practices which could result in minor personal injury or product or property damage.

FOR SAFETY: To identify actions which must be followed for safe operation of equipment.

Report machine damage or faulty operation immediately. Do not use the machine if it is not in proper operating condition. Following is information that signals some potentially dangerous conditions to the operator or the equipment. Read this information carefully. Know when these conditions can exist. Locate all safety devices on the machine. Please take the necessary steps to train the machine operating personnel.

FOR SAFETY:

DO NOT OPERATE MACHINE:

Unless Trained and Authorized.

Unless Operation Guide is Read and understood.

In Flammable or Explosive areas.

In areas with possible falling objects.

WHEN SERVICING MACHINE:

Avoid moving parts. Do not wear loose clothing; jackets, shirts, or sleeves when working on the machine.

SAFETY LABEL LOCATION

NOTE: These drawings indicate the location of safety labels on the machine. If at any time the labels become illegible, promptly replace them.



LABEL WARNING
86242230
PRV NO. 500009

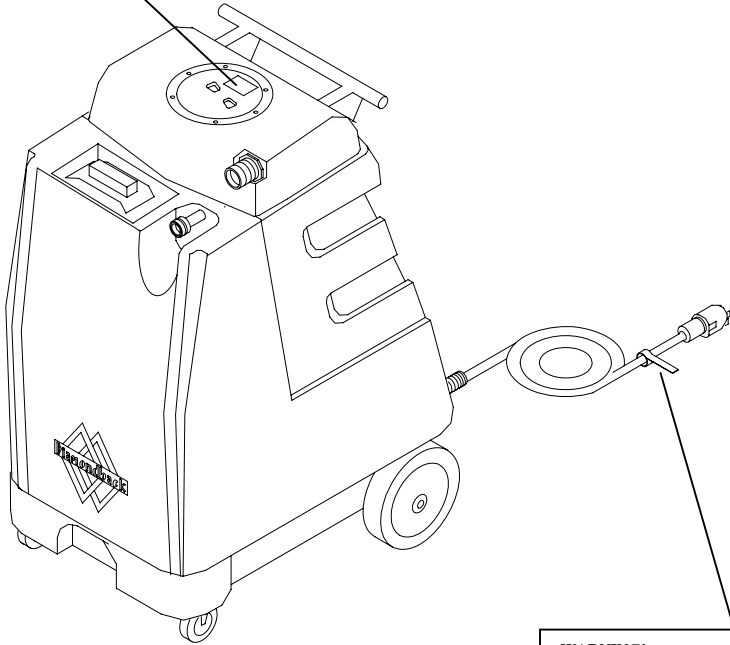

LABEL CIRCUIT INTERRUPTER
86200570
PRV NO. 170-41

GROUNDING INSTRUCTIONS

THIS PRODUCT IS FOR COMMERCIAL USE ONLY.

ELECTRICAL:

In the USA this machine operates on a standard 15 amp 115V, 60 hz, A.C. power circuit. The amp, hertz, and voltage are listed on the data label found on each machine. Using voltages above or below those indicated on the data label will cause serious damage to the motors.

EXTENSION CORDS:

If an extension cord is used, the wire size must be at least one size larger than the power cord on the machine, and must be limited to 50 feet (15.5m) in length.

GROUNDING INSTRUCTIONS:

This appliance must be grounded. If it should malfunction or break down, grounding provides a path of least resistance for electric current to reduce the risk of electric shock. This appliance is equipped with a cord having an equipment-grounding conductor and grounding plug. The plug must be inserted into an appropriate outlet that is properly installed and grounded in accordance with all local codes and ordinances.

This appliance is for use on a nominal 120-volt circuit, and has a grounded plug that looks like the plug in "Fig. A". A temporary adaptor that looks like the adaptor in "Fig. C" may be used to connect this plug to a 2-pole receptacle as shown in "Fig. B", if a properly grounded outlet is not available. The temporary adaptor should be used only until a properly grounded outlet (Fig. A) can be installed by a qualified electrician. The green colored rigid ear, lug, or wire extending from the adaptor must be connected to a permanent ground such as a properly grounded outlet box cover. Whenever the adaptor is used, it must be held in place by a metal screw.

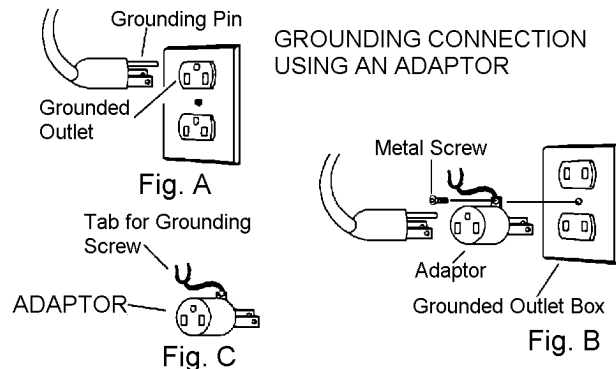

Note: Adaptors are not allowed in Canada.

Improper connection of the equipment-grounding conductor can result in a risk of electric shock. Check with a qualified electrician or service person if you are in doubt as to whether the outlet is properly grounded. Do not modify the plug provided with the appliance - if it will not fit the outlet, have a proper outlet installed by a qualified electrician.

THIS PAGE LEFT BLANK INTENTIONALLY

TECHNICAL SPECIFICATIONS

ITEM	MEASURE
ELECTRICAL	115 Volt, 60 hz
Vacuum Motor	Dual 2 stage
Solution Pump	100 psi
	200 psi
Solution Capacity	16 gal (60 L)
Recovery Capacity	14 gal (53 L)
Weight- Empty	95 lbs (210 kg)
Weight-Full Solution	230 lbs (510 kg)
Height	37 inches (93.98 cm)
Length	27 inches (68.58 cm)
Width	20 inches (50.80 cm)
Power cord	22 feet (6.71 m)

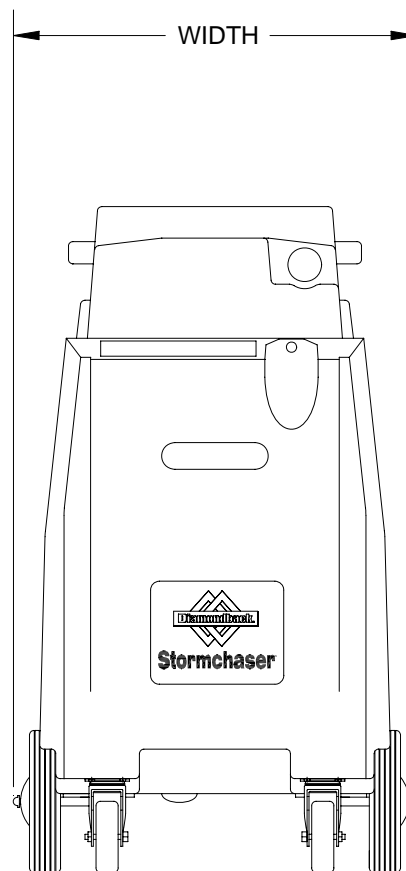
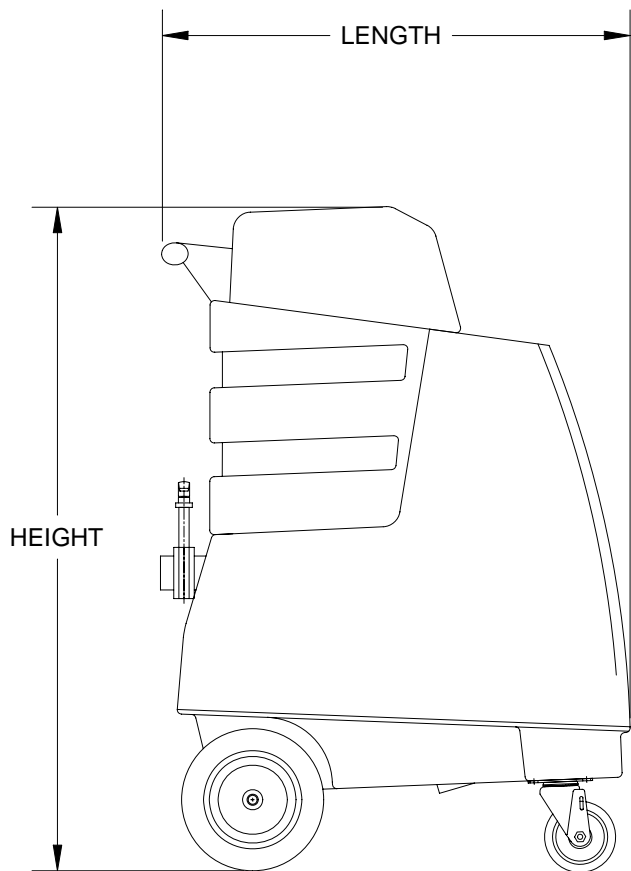

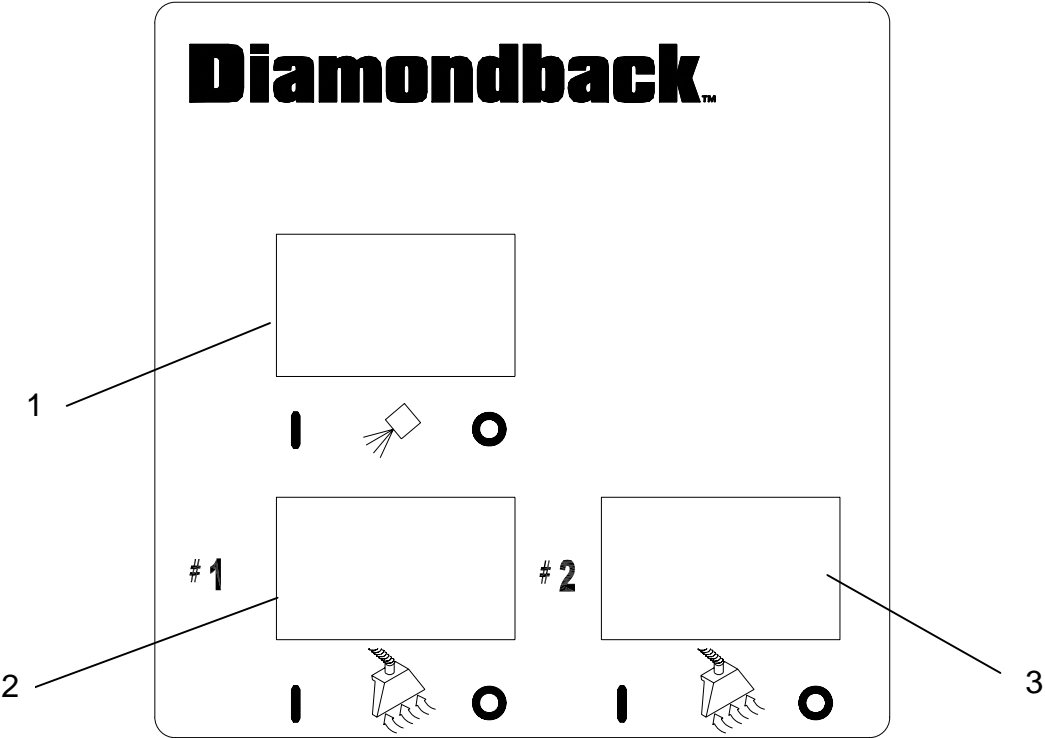

-
- 1. Pump Switch
 - 2. Vacuum #1 Switch
 - 3. Vacuum #2 Switch

MACHINE OPERATION

PRE-RUN INSPECTION

1. Check all fittings and connectors for proper assembly.
2. Check all hoses for leaks. Repair or replace any damaged hoses.
3. Check power cord(s) for any damage. If damaged, replace.

EQUIPMENT SET-UP

1. Plug power cord from machine into properly grounded wall outlet.
2. Turn vacuum motor switch on and off to make sure there is electrical power at machine.
3. Connect vac hose to machine. Slide the swivel cuff over the outlet on the tank.
4. Connect the hose to your machine and wand. Pull back the knurled collar on the quick disconnect coupler and push onto the connection on the chassis. To avoid leaks, check to be that a positive connection was made.
5. Pour clean, hot water into the solution tank.
To avoid possible tank distortion, water temperature must not exceed 140 F (60C).
6. Add a non-foaming cleaning solution concentrate, for use in hot water extractors at the proportions noted on the container (See list below), into solution tank. **NOTE: When using powder cleaner, pre-mix with hot water in a clean container before adding to the solution tank.**
7. Turn pump and vacuum switch(s) to the on position. **NOTE: Pump may need to be primed for solution flow.** (see Priming the Pump)
8. Start cleaning.

WARNING:

To prevent possible disease hazard, before attempting to clean bodily fluids spills, you must kill any viruses, germs or bacteria present in the bodily fluid.

SUITABLE CHEMICALS

Alkalis
Clorox II Bleach*
Defoaming Agents
Detergents
Hydroxides
Oxygen Bleaches
Soaps
Sta-Puf Fabric
Softener*
Vinegar

INCOMPATIBLE CHEMICALS

Aldehydes
Aromatic Hydrocarbons
Butyls
Carbon Tetrachloride
Clorox*
Chlorinated Bleaches
Chlorinated Hydrocarbons
D-Limonene
Lysol*
Methyls (MEK)
Perchloroethylene (perc)
Phenols
Trichloroethylene

PRIMING THE PUMP

1. Connect priming hose to solution output on machine.
2. Run open end of priming hose to vacuum intake.
3. Turn pump and both vacuums on and seal off hose going into vacuum in take.
4. Do this for 30 seconds or until pump is putting out a steady flow of water.

*Registered Trademark

EMPTYING AND CLEANING

⚠ WARNING: Always use defoamer if foaming occurs. Foam will suspend large particles that may damage vacuum(s) as well as allow liquid into the vacuum motor(s) without activating the float shutoff.

1. Before proceeding, make certain that the nozzle is functioning properly.
 - a. To check, hold the wand about one foot above the surface to be cleaned and open the wand valve. A full spray should be observed from the nozzle.
 - b. If the nozzle is not showing a full spray pattern, adjust nozzle for proper pattern, clean, or replace nozzle.
2. Normally, chemical is applied on the **push** stroke while vacuuming is done on the **pull** stroke. For heavily soiled carpets the hand tool may be used in the scrubbing manner, applying chemical in both the push and pull stroke. **ALWAYS FINISH UP AN AREA WITH A VACUUM PULL STROKE.**
3. When cleaning, keep the working opening (wand mouth) flat on the surface being cleaned. Keep the wand moving when the valve is open.
4. The shutoff float inside the recovery tank will impede the vacuum flow when the tank is full. When this occurs, empty the recovery tank. Do this by opening the dump valve located at the back of the machine. **NOTE:** *Dispose of waste in a proper manner which would not violate any Local, State or Federal law.*
5. Once the recovery tank has been emptied, you may once again proceed with cleaning.

⚠ CAUTION

Operating Vacuum after shutoff has activated could draw water directly into the vac motor. This will cause damage to the motor, therefore voiding your warranty.

⚠ CAUTION

ALWAYS TEST CARPET FOR COLOR FASTNESS IN AN INCONSPICUOUS PLACE. Also, to avoid prolonged drying times, do not spray too much solution in any one area.

SHUT DOWN AND STORAGE

1. Turn Switch OFF. Empty recovery tank completely and rinse several times to remove any dirt or debris that may be left behind.
2. Drain any unused cleaning solution from solution tank and rinse with clean water to remove any suds left behind by the cleaning chemicals. **NOTE:** *Dispose of waste in a proper manner which would not violate any Local, State or Federal law*
3. Run a small amount of clean water through pump if chemicals were used. This will help insure the life of your pump.
4. Check the spray jet on the cleaning tool for full spray pattern and inspect vac head for any obstructions.
5. Remove as much moisture from system before storing in cold climates. Excess water may freeze during storage and crack internal components, causing damage to the unit.

⚠ WARNING

Before making any adjustments or performing any maintenance to your machine, disconnect the power cord from the electrical source.

MAINTENANCE

DAILY MAINTENANCE



Unplug power cord(s) before servicing or making any repairs.

1. Flush the entire system, including floor tool, hand tool, etc., with 1 to 3 gallons of clean, hot water.
2. Vacuum out the solution tank.
3. Rinse tank with fresh water. Periodically inspect the recovery tank and decontaminate if necessary, using a Hospital Grade Virucide or a 1-10 bleach to water solution. Wastewater should be disposed of properly.
4. Occasionally check filter screen at the bottom of the solution tank and rinse clean with hot water if necessary.
5. Inspect hoses for wear. Frayed or cracked hoses should be replaced to avoid vacuum or solution pressure loss.
6. Inspect power cord for wear or damage. This cable will lie on wet carpet. To prevent electrical shock replace cords that are frayed or have cracked insulation immediately.
7. Clean all dirt and obstructions from drain valve and gaskets to prevent possible leakage and premature wear.
8. Run clean water through solution pump when work is complete.
9. Empty both tanks and rinse, run vacuum (s) for at least one minute to dry motor(s).
10. Store with access covers removed to allow tanks to dry.

PERIODIC MAINTENANCE

1. Twice a month, flush a white vinegar solution (one quart vinegar to two gallons water) or anti-browning solution (mixed as directed) through the extractor. This will prevent build-up of alkaline residue in the system.
2. If spray jet becomes clogged, remove the spray tip, wash it thoroughly, and blow dry. **NOTE: Do NOT USE PINS, WIRE, ETC. TO CLEAN NOZZLE AS THIS COULD DESTROY THE SPRAY PATTERN.**
3. Apply silicone lubricant to solution nipple.
4. Periodically inspect all hoses, electrical cable and connections on your machine. Frayed or cracked hoses should be repaired or replaced to eliminate vacuum or solution pressure loss. If the cable insulation on the power cord is broken or frayed, repair or replace immediately. Don't take chances with electrical fire or shock.
5. Clean outside of all tanks and check for damage.

MONTHLY MAINTENANCE

1. Check all bearings for noise and wear.
2. Check all gaskets for wear and leakage.
3. Check pump pressure; observe spray pattern and check gauge if necessary.
4. Check overall performance of machine.

SEMI-ANNUALLY

1. Check vacuum motor brushes.

LUBRICATION

For hose fitting lubrication, use a light silicone lubricant which will not damage o-rings.

STORAGE

Thoroughly clean machine if it is to be stored. Protect this machine from freezing while in storage.

⚠ WARNING:

Only qualified maintenance personnel are to perform the following repairs.

SOLUTION PUMP REPLACEMENT

1. Turn off all switches and unplug the machine.
2. Remove knobs holding recovery tank to solution tank.
3. Remove recovery tank to gain access to the pump in base of solution tank.
4. Remove solution hoses from fittings on pump. Disconnect wires.
5. Remove the screws that fasten the pump to the solution tank.
6. Reverse process to install new replacement pump.

VACUUM MOTOR REPLACEMENT

1. Turn off all switches and unplug machine.
2. Remove knobs holding recovery tank to solution tank.
3. Tip recovery tank to expose one vacuum while other is located in base of solution tank.
4. Locate the proper vacuum motor wires and disconnect.
5. Unfasten screws holding vacuum to plate.
6. Remove the vacuum motor.
7. Reverse process to install vacuum motor replacement.

Vacuum Motor Carbon Brushes Replacement (Windsor)

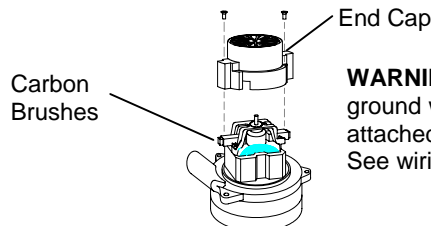

If armature commutator is grooved, extremely pitted or not concentric, the motor will need to be replaced or sent to a qualified service center.

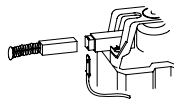

Important:
These brushes wear quicker as the length shortens due to increased heat. Spring inside brush housing will damage motor if brushes are allowed to wear away completely.

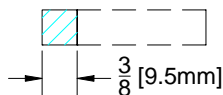

Periodically check the length of the carbon brushes. Replace both carbon brushes when either is less than 3/8" (9.5mm) long.

Vacuum Motor Carbon Brushes Replacement (Ametek)

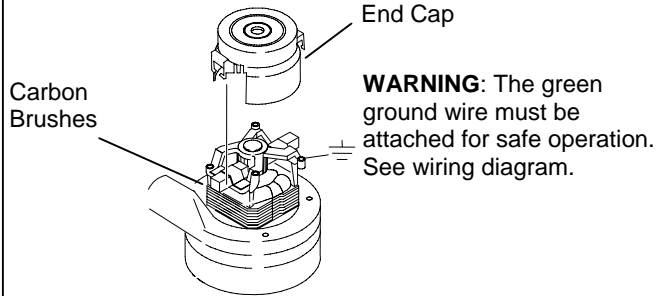

Note: When replacing carbon brushes loosen wire terminal BEFORE removing screws on bracket.

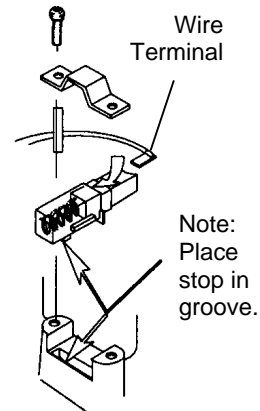

If armature commutator is grooved, extremely pitted or not concentric, the motor will need to be replaced or sent to a qualified service center.

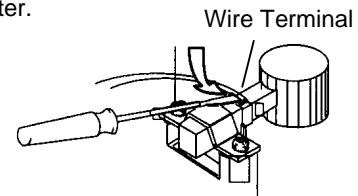

Important:
These brushes wear quicker as the length shortens due to increased heat. Spring inside brush housing will damage motor if brushes are allowed to wear away completely.

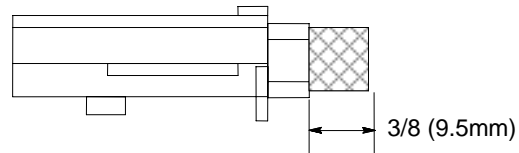

Periodically check the length of the carbon brushes. Replace both carbon brushes when either is less than 3/8" (9.5mm) long.

MAINTENANCE

PUMP REPLACEMENT PARTS FOR SHURFLO 100 PSI 86201430 – PRV NO. (250-64A)

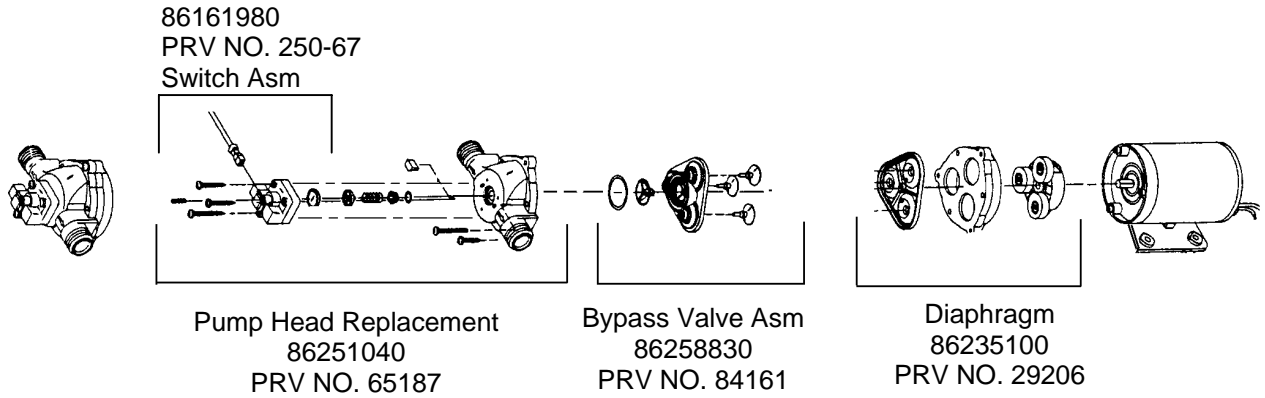

PUMP REPLACEMENT PARTS FOR FLOJET 100 PSI 86251110 – PRV NO. (65219)

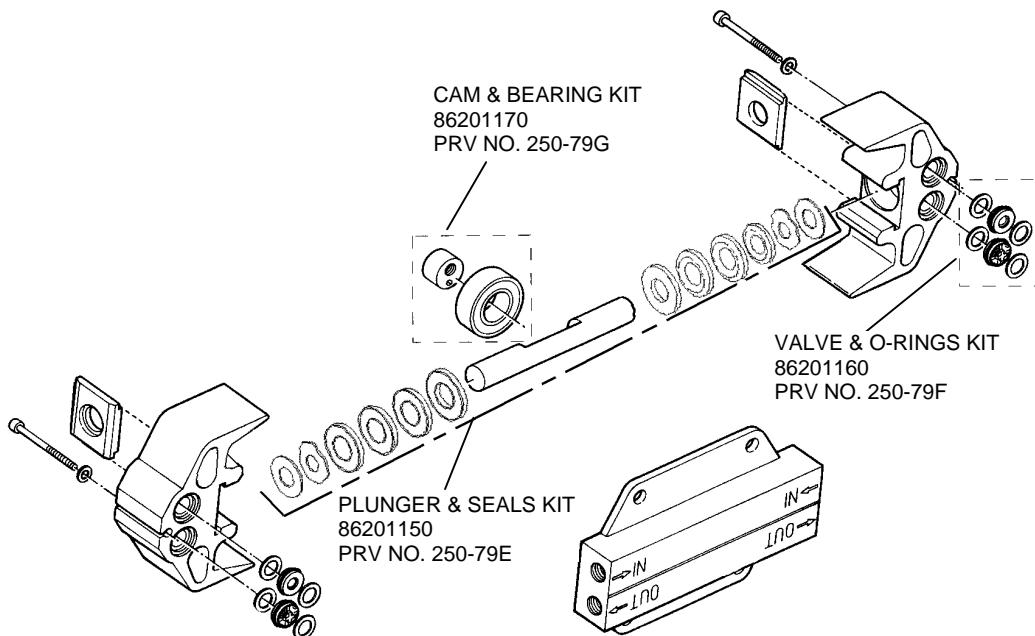
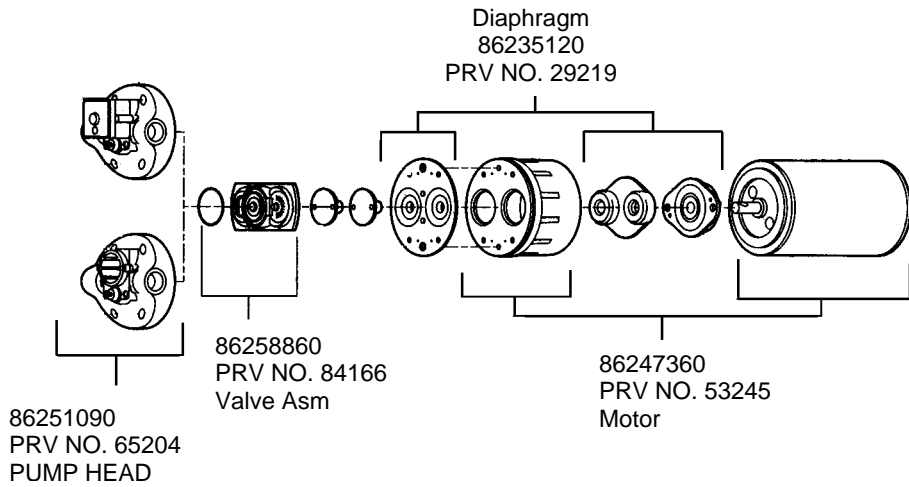

PRESSURE REGULATOR

For best results with the pressure regulator, we recommend that you clean and lubricate the piston and u-cup with Superlube lubricant monthly or when pressure drop seems excessive.

1. Turn unit off before lubricating.
2. Remove cap, spring and spring retainer plate.
3. With fingertips remove piston and u-cup.
4. Wipe piston and u-cup clean of any film or scale.
5. Lubricate the piston and u-cup with Superlube.
6. Reassemble regulator.
7. With pump ON, re-adjust pressure regulator for normal operation.

LUBRICATE U-CUP WITH SUPERLUBE MONTHLY.

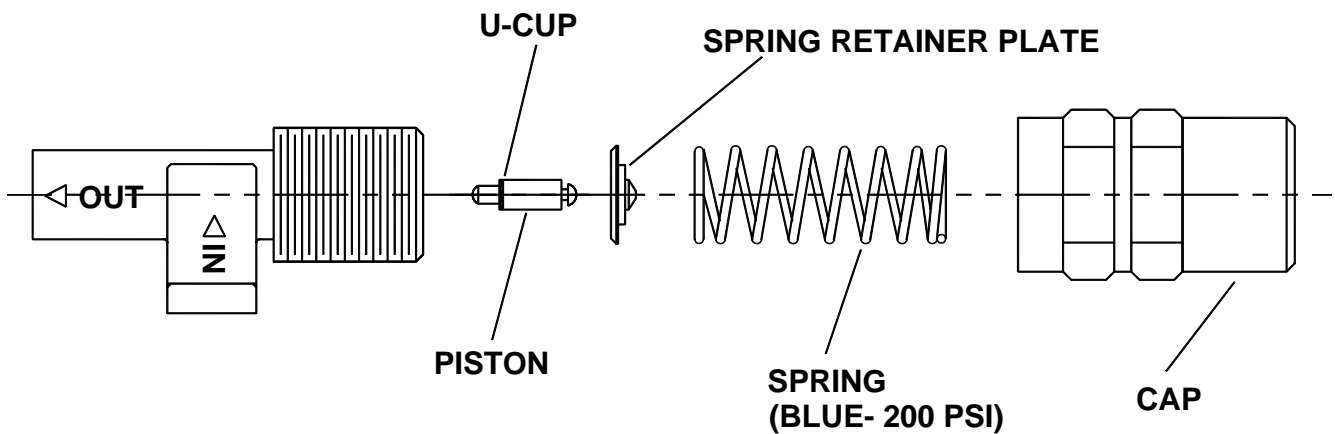

TROUBLESHOOTING

PROBLEM	CAUSE	SOLUTION
Loss of Power	Dead electrical circuit	Check building circuit breaker or fuse box.
	Faulty power cord	Replace
Electrical shock	Equipment not grounding	Follow grounding instructions exactly
	Receptacle not grounded	Contact an electrician to check building's wiring
	Internal wiring problem	Have a trained service technician check machine's wiring
Vac motor speed varies or doesn't run	Worn motor brushes	Replace
	Motor worn out	Replace
	Faulty switch	Replace
Loss of vacuum	Loose vacuum dome	Center and seal dome over tank
	Crack in dome of poor joint	Replace or repair using acrylic plastic cement only
	Lint or dirt clogging vacuum screen	With power off clean screen
	Loose cuffs on vacuum hose	Tighten cuffs turning counterclockwise
	Vac motor seals leaking	Replace
	Floor tool vac chamber clogged	Wash out with hose. Pick lint out with a wire
	Vac motor, hose, or dome gasket	Replace
Pump runs no solution	Pump inlet screen plugged	Clean inlet screen
	Pump air locked	Press trigger to open valve on cleaning wand to relieve air
	Internal or external solution line damaged and leaking	Replace
	Pump not primed	Prime pump with provided hose (pg. 3-3)
Pump runs, loss of pressure	Internal pump components wearing out	Replace, see pump kit components (pg 4-3)
	Check valves in pump head for particles or cuts in seals	Take piston from BPR and lubricate with Superlube. If problem still exists change BPR kit
Pump will not run	Unit not plugged in	Connect unit to 3 prong grounded outlet
	Loose wiring	See dealer
Solution hose fitting hard to connect	Corrosion on fittings.	Clean with steel wool. Soak in acetic acid (white vinegar). Lubricate lightly with silicone base lubricant.
Carpet not getting clean	Severe soil conditions	Make several passes at right angles to each other. Use a pre-spray.
Carpet too wet	Over saturation	Adjust solution pressure to lower settings. Make several passes without spray
Carpet browning	Leaving carpet too wet	Check for loss of vac pressure
	Too much chemical	Check label for correct solution concentration
	Light carpet with no brown prevention	Go over carpet with browning prevent only
Solution not flowing properly	Solution hose connection	Check for positive connection
	Faulty pump	Repair or replace
	Faulty floor tool valve	Repair or replace
	Faulty pump switch	Repair

THIS PAGE LEFT BLANK INTENTIONALLY

CONTROL PANEL GROUP

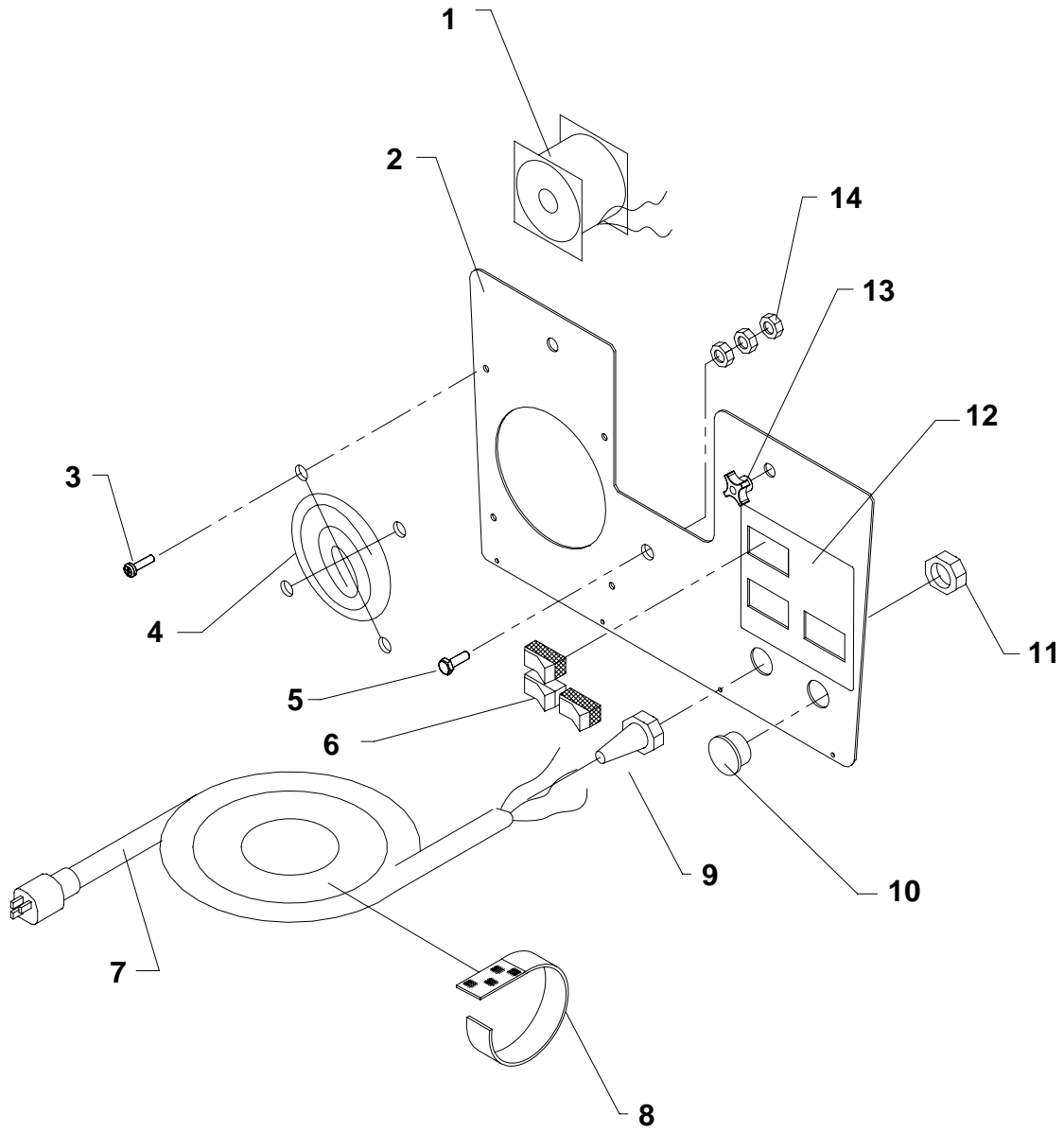

CONTROL PANEL GROUP

REF	PART NO.	PRV NO.	QTY	DESCRIPTION	SERIAL NO. FROM	NOTES:
1	86199650	070-08	1	FAN, 105 CRM AXIAL		
2	86090900	62899	1	PANEL ASM., CONT. 2 SW W/HEAT		
3	86276290	70626	4	SCR, #10 X 3/4 PPHST HI-LO BLK		
4	86199660	070-08A	1	FAN FINGER GUARD		
5	86273810	70018	1	SCR, 1/4-20 X 1 HHCS SS		
6	86256960	72142	3	SWITCH, SPST 15A EURO ROCKER		
7	86199540	060-04A	1	CORD 25' BLK 14/3 SJTW/A PLUG		
8	86202160	320-05	1	VELCRO STRAP		
9	86256180	73195	1	STRAIN RELIEF, 1/2 NPT (.48ID)		
10	86199310	110-14	1	CAP PLUG 7/8"		
11	86005670	57040	1	NUT, 1/2 NPT CONDUIT		
12	86200610	500346	1	LABEL D/B 3 SWITCH W/HEAT		
13	86200500	140-11	2	KNOB RT/TANK		
14	86005710	57105	3	NUT, 1/4-20 HEX W/STAR WASHER		

FRAME GROUP (100 PSI)

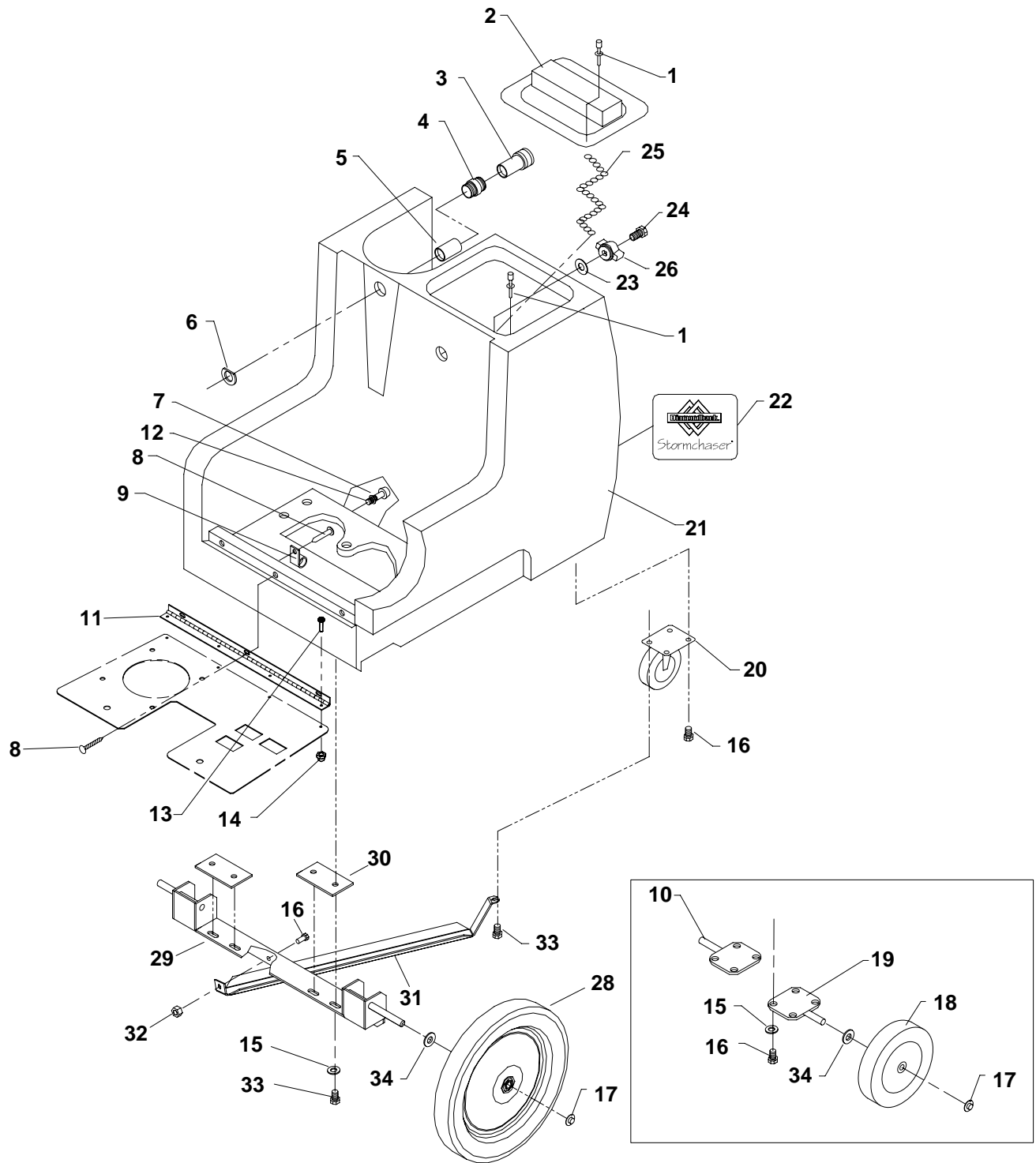

FRAME GROUP (100 PSI)

REF	PART NO.	PRV NO.	QTY	DESCRIPTION	SERIAL NO. FROM	NOTES:
1	86201290	280-02	2	RIVET AL. 3/16 X 1/2 CLOSED		
2	86201500	260-71	1	SOLUTION COVER D/B		
3	86002450	22015	1	COUPLER, 1/4 OD		
4	86005590	56014	1	NIPPLE, 1/4 CLOSE		
5	86197350	22014	1	COUPLER, 1/4F HEX		
6	86091260	87217	1	WASHER, 9/16 ID BENT		
7	86201590	290-08	1	SOL. SCREEN (ACORN) W/RUB BASE		
8	86210210	70162	4	SCR, 10-32 X 3/8 PPHMS SS		
9	86198460	20008	1	CLAMP, 5/8 NYLON UL/CSA		
10	86090710	010-02	1	AXLE ASM, RIGHT		
11	86200020	41393	1	HINGE, ACCES PANEL		
12	86240430	40083	1	HOSEBARB, 3/8MT X 3/8 NYLON		
13	86006620	70127	4	SCR, 6-32 X 1/4 PPHMS SS		
14	86271350	57187	4	NUT, 6-32 ACORN, ZINC		
15	86010630	87013	4	WASHER, 1/4 X 5/8 OD SS		
16	86273830	70020	8	SCR, 1/4-20 X 1/2 HHCS SS		
17	86271380	57196	2	NUT, 1/2 PUSH-ON DOME CAP		
18	86202250	040-06	2	WHEEL 8" BLK CENTERED HUB		
19	86090700	010-01	1	AXLE ASM, LEFT		
20	86199430	040-03	2	CASTER SWIVEL 4"		
21	86033430	75335	1	TANK, SOLUTION DB BLK 100 PSI		
22	86200630	500350	1	LABEL, STORMCHASER MAIN		
23	86202240	390-24	2	WASHER, 1/4 X 5/8 BONDED NEOPRN		
24	86276270	70619	1	SCR, 1/4-20 X 2.0 HHMS SS F/T		
25	86232790	27912	1	CHAIN ASM, #10 BEAD S/S W/EYES		
26	86242130	48100	1	KNOB, HEX PRESS LOC WING		
27	86270900	57037	1	NUT, 1/4-20 WING SS		NOT SHOWN
28	86202280	89252	2	WHEEL, 12" BLK CNTRD HUB	1000137325	
29	86091430	05253	1	AXLE ASSEMBLY D.B.	1000137325	
30	86079100	620065	2	PLATE AXLE	1000137325	
31	86070910	140758	1	BRKT 12" WHEEL MNT BRACE	1000137325	
32	86005710	57105	1	NUT, 1/4 -20 HEX W/STAR WASHER		
33	86020310	70015	5	SCR, 1/4-20 X 3/4 HHCS SS NP		
34	86010710	87080	2	WASHER, .5 X 1.25 FLAT GR8 PLT		

FRAME GROUP (200 PSI)

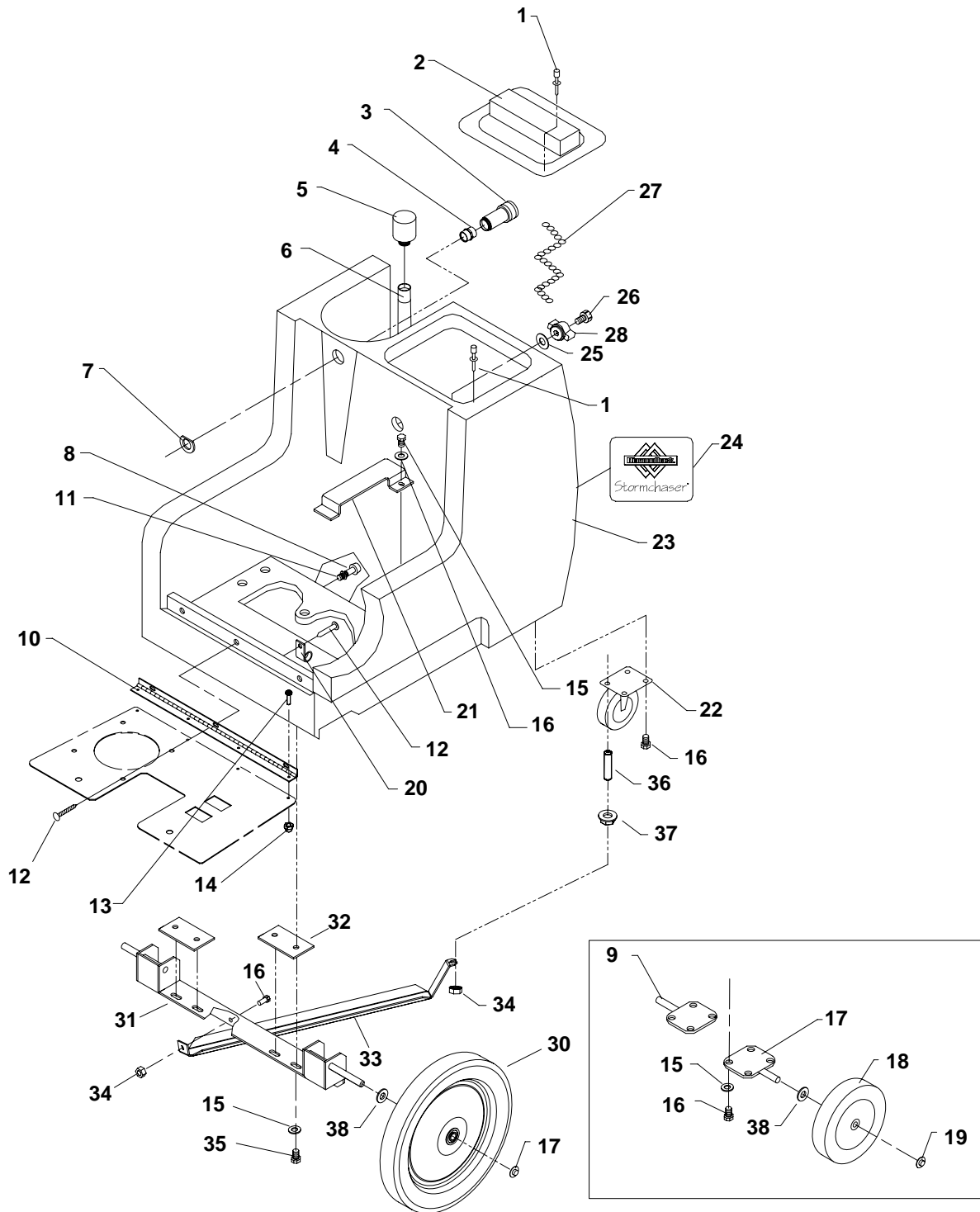

FRAME GROUP (200 PSI)

REF	PART NO.	PRV NO.	QTY	DESCRIPTION	SERIAL NO. FROM	NOTES:
1	86201290	280-02	2	RIVET AL. 3/16 X 1/2 CLOSED		
2	86201500	260-71	1	SOLUTION COVER D/B		
3	86002450	22015	1	COUPLER, 1/4 OD		
4	86005590	56014	1	NIPPLE, 1/4 CLOSE		
5	86199580	250-35	1	D/B BPR 200PSI		
6	86200250	151-50B	1	HOSE, 42" GRY3/8 1/4MPTXCUT		
7	86091260	87217	1	WASHER, 9/16OD BENT		
8	86201590	290-08	1	SOL SCREEN (ACORN) W/RUB BASE		
9	86090710	010-02	1	AXLE ASM, RIGHT		
10	86200020	41393	1	HINGE, ACCESS PANEL		
11	86240430	40083	1	HOSEBARB, 3/8MT X 3/8 NYLON		
12	86274290	70162	4	SCR, 10-32 X 3/8 PPHMS SS		
13	86006620	70127	3	SCR, 6-32 X 1/4 PPHMS SS		
14	86271350	57187	4	NUT, 6-32 ACORN ZINC		
15	86010630	87013	8	WASHER, 1/4ID X 5/8OD SS		
16	86020360	70020	17	SCR, 1/4-20 X 1/2 HHCS SS		
17	86090700	010-01	1	AXLE ASM, LEFT		
18	86202250	040-06	2	WHEEL 8" BLK CENTERED HUB		
19	86202250	57196	2	NUT, 1/2 PUSH-ON DOME CAP		
20	86198460	20008	1	CLAMP, 5/8 NYLON UL/CSA		
21	86099840	065-28	1	DIAMONDBACK 200 PUMP SUPPORT		
22	86199430	040-03	2	CASTER SWIVEL 4" SWIVEL		
23	86033440	75336	1	TANK, SOLUTION DB BLK 200 PSI		
24	86200630	500350	1	LABEL, STORMCHASER MAIN		
25	86202240	390-24	2	WASHER 1/4 X 5/8 BONDED NEOPRN		
26	86276270	70619	1	SCR, 1/4-20 X 2.0 HHMS SS F/T		
27	86232790	27912	1	CHAIN ASM, #10 BEAD SS W/EYES		
28	86242130	48100	1	KNOB, HEX PRESS LOC WING		
29	86270900	57037	1	NUT, 1/4-20 WING SS		NOT SHOWN
30	86202280	89252	2	WHEEL, 12" BLK CNTRD HUB	1000137325	
31	86091430	05253	1	AXLE ASSEMBLY D.B.	1000137325	
32	86079100	620065	2	PLATE AXLE	1000137325	
33	86070910	140758	1	BRKT 12" WHEEL MNT BRACE	1000137325	
34	86005710	57105	2	NUT, 1/4 -20 HEX W/STAR WASHER		
35	86273780	70015	4	SCR, 1/4-20 X 3/4 HHCS SS NP		
36	86006850	70393	1	SET SCR, 1/4-20 X 1.25		
37	86271370	57189	1	NUT, 1/4-20 FLANGE LOCK		
38	86010710	87080	2	WASHER, .5 X 1.25 FLAT GR8 PLT		

PUMP GROUP (100 PSI)

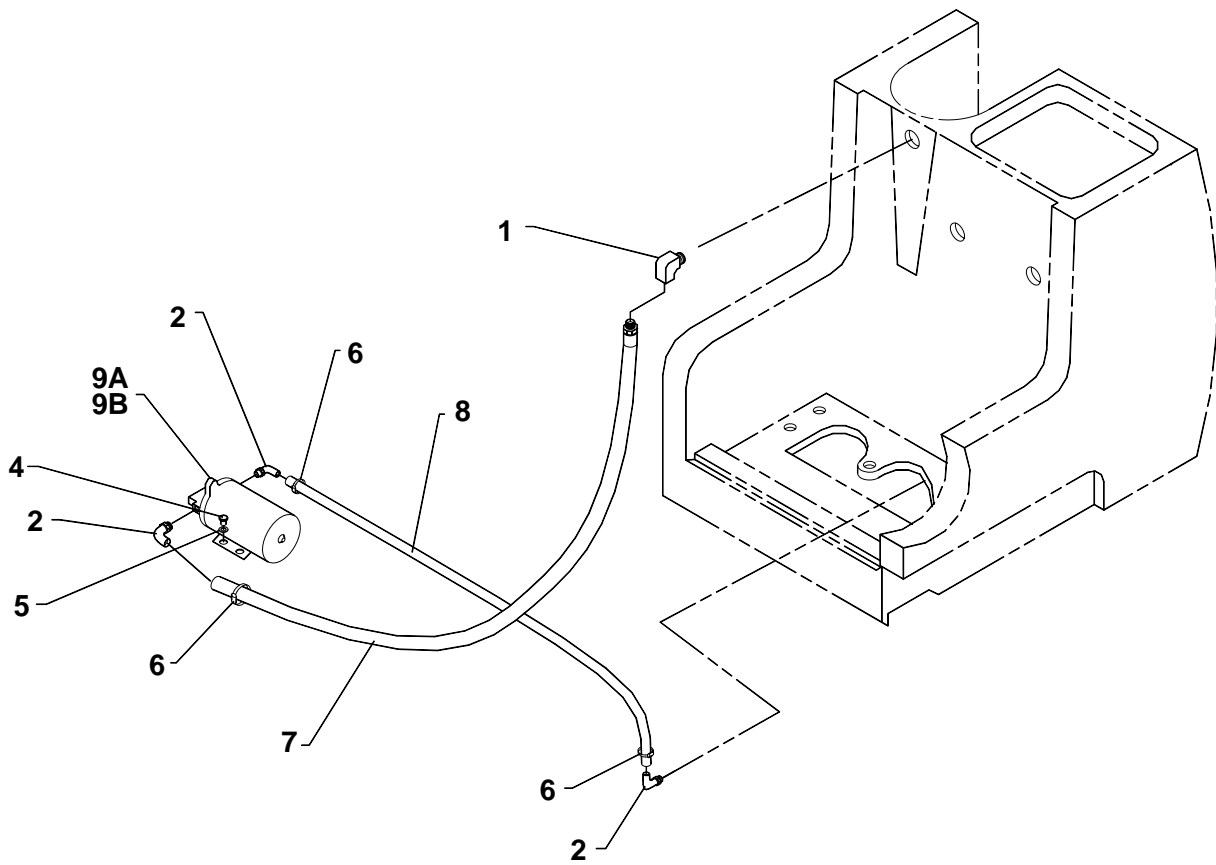

PUMP GROUP (100 PSI)

REF	PART NO.	PRV NO.	QTY	DESCRIPTION	SERIAL NO. FROM	NOTES:
1	86199640	030-16	1	ELBOW, 1/4 NPT STREET LONG 90D		
2	86001550	40043	3	HOSEBARB, 3/8MPT X 3/8 P0D		
3	-	OPEN	-	-		
4	86020340	70018	2	SCR, 1/4-20 X 1 HHCS SS		
5	86010630	87013	2	WASHER, 1/4 ID X 5/8 OD SS		
6	86233150	20042	3	CLAMP, 3/8 HOSE (D-SLOT)		
7	86200230	151-48B	1	HOSE, 52.5 GRY 3/8 1/4MPTXCUT		
8	86280830	39036	1	HOSE, 3/8 NYLOBRAID X 12"		
9A	86201430	250-64A	1	SHURFLO 100 PSI PUMP DEMAND		
9B	86251110	65219	1	PUMP, 115V 100 PSI BYPASS W/SW (FLOJET)		

PUMP GROUP (200 PSI)

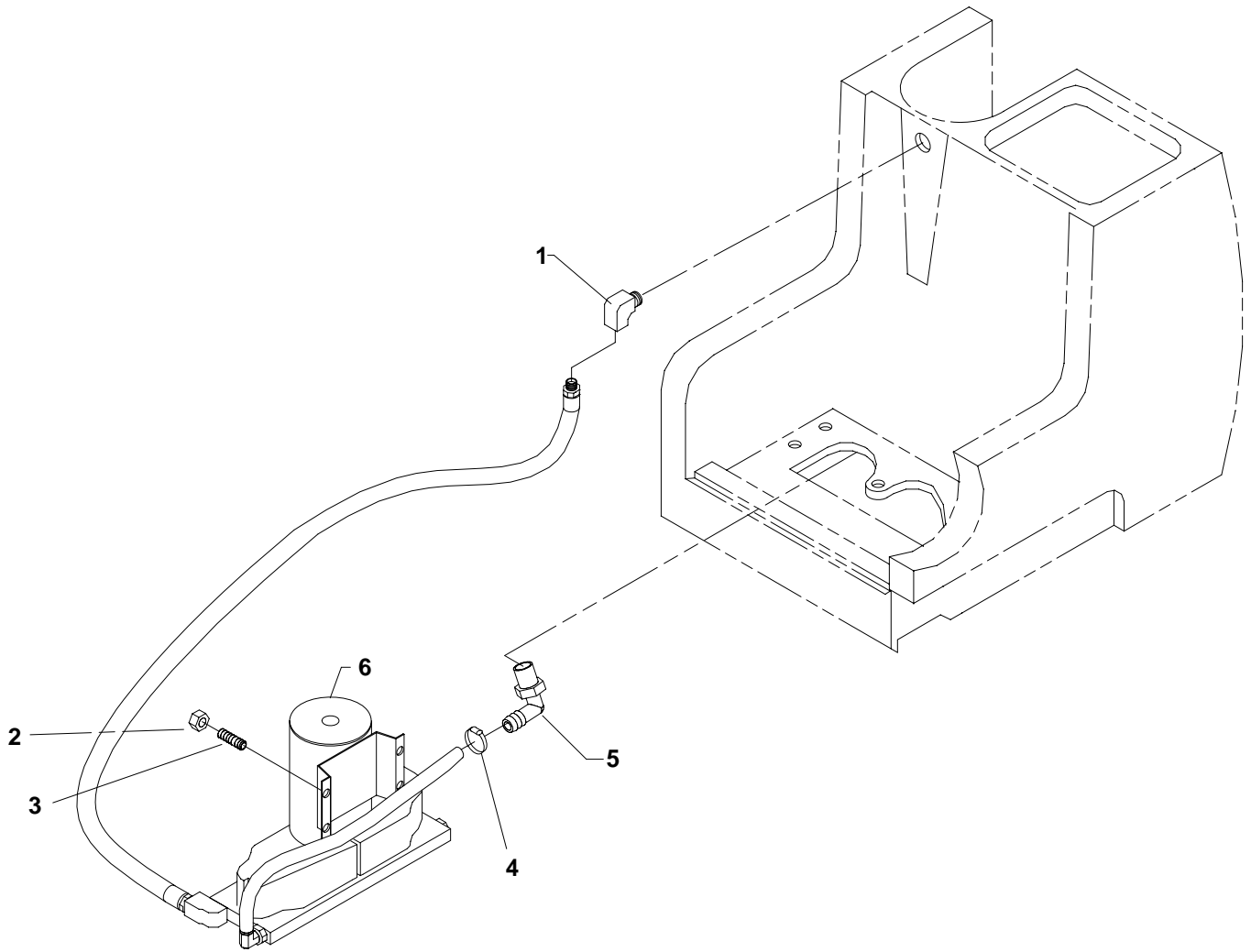

PUMP GROUP (200 PSI)

REF	PART NO.	PRV NO.	QTY	DESCRIPTION	SERIAL NO. FROM	NOTES:
1	86199640	030-16	1	ELBOW, 1/4 NPT STREET LONG 90D		
2	86006850	70393	2	SET SCR, 1/4-20 X 1.25L		
3	86005710	57105	2	NUT, 1/4-20 HEX W/ STAR WASHER		
4	86222770	20042	1	CLAMP, 3/8 HOSE (D-SLOT)		
5	86197940	40027	1	HOSEBARB, 3/8 MPT X 1/2 90° DL		
6	86201210	65209	1	PUMP ASM, 200PSI N/H D.B.		

RECOVERY TANK GROUP

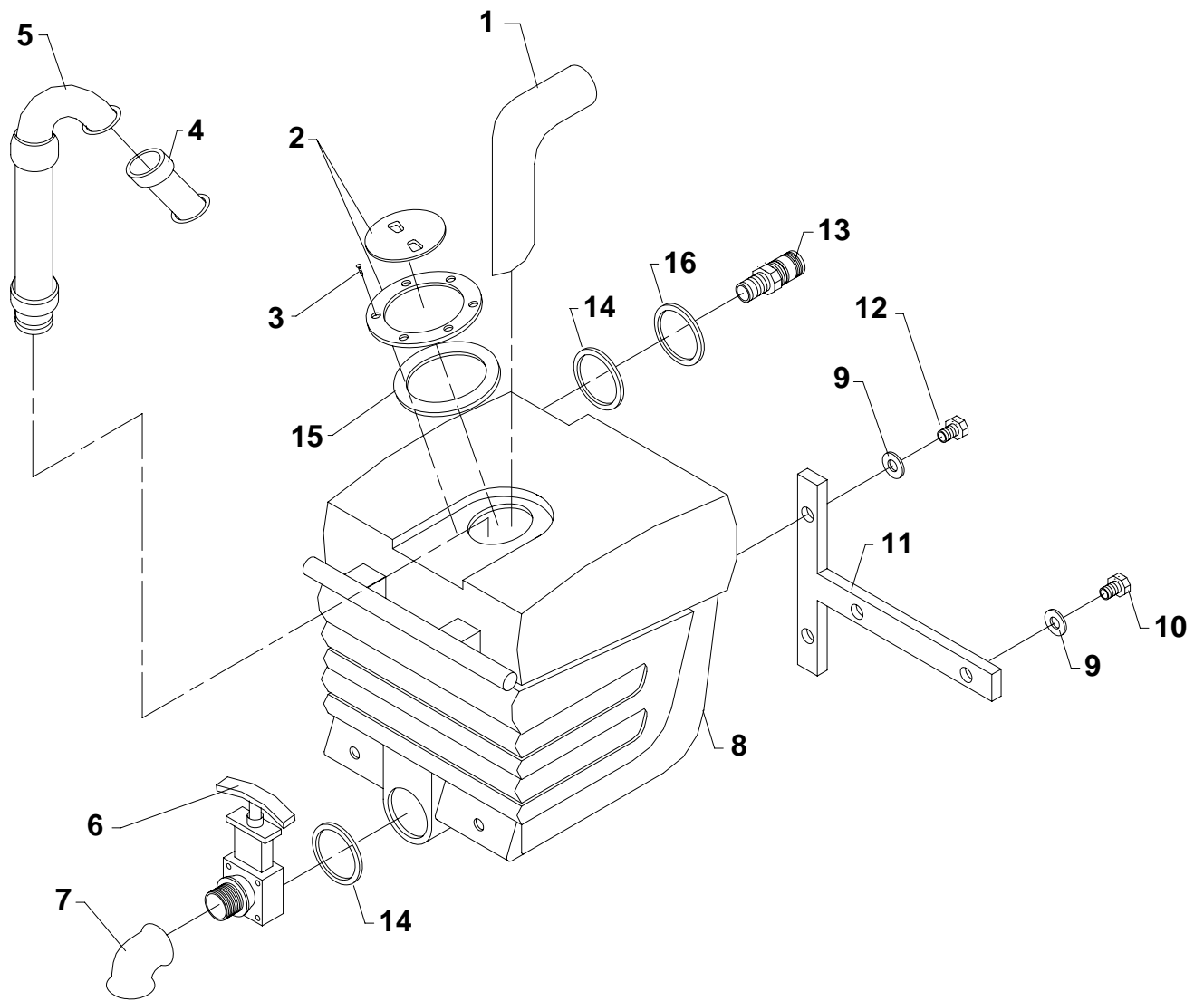

RECOVERY TANK GROUP

REF	PART NO.	PRV NO.	QTY	DESCRIPTION	SERIAL NO. FROM	NOTES:
1	86033260	05151	1	TUBE ASM, RECOVERY TANK		
2	86002620	260-64A	1	ACCESS COVER CLEAR 6" W/RIM		
3	86275800	70546	6	SCR, 8 X 3/4 PFHT/S BLK ZINC		
4	86199840	090-12A	1	FLOAT CAGE ASSY COMPLETE SLIP		
5	86033330	78475	1	VAC STACK ASM		
6	86161460	15-808123	1	DUMP VALVE, 2"		
7	86161470	11-800444	1	ELBOW, 2" 45D PVC SCH40		
8	86033420	75334	1	TANK, RECOVERY DB DK GREY		
9	86010630	87013	4	WASHER, 1/4 ID X 5/8 OD SS		
10	86273780	70015	2	SCR, 1/4-20 X 3/4 HHCS SS		
11	86091150	065-25	1	TANK BRACE ASM, D/B		
12	86273830	70020	2	SCR, 1/4-20 X 1/2 HHCS SS		
13	86200290	260-33	1	HOSEBARB, 1.5MPT X 1.5		
14	86237770	35256	2	GASKET, DUMP VALVE		
15	86004000	35255	1	GASKET, TANK LID		
16	86090320	87257	1	WASHER, HOSEBARB		

VACUUM GROUP (UPPER)

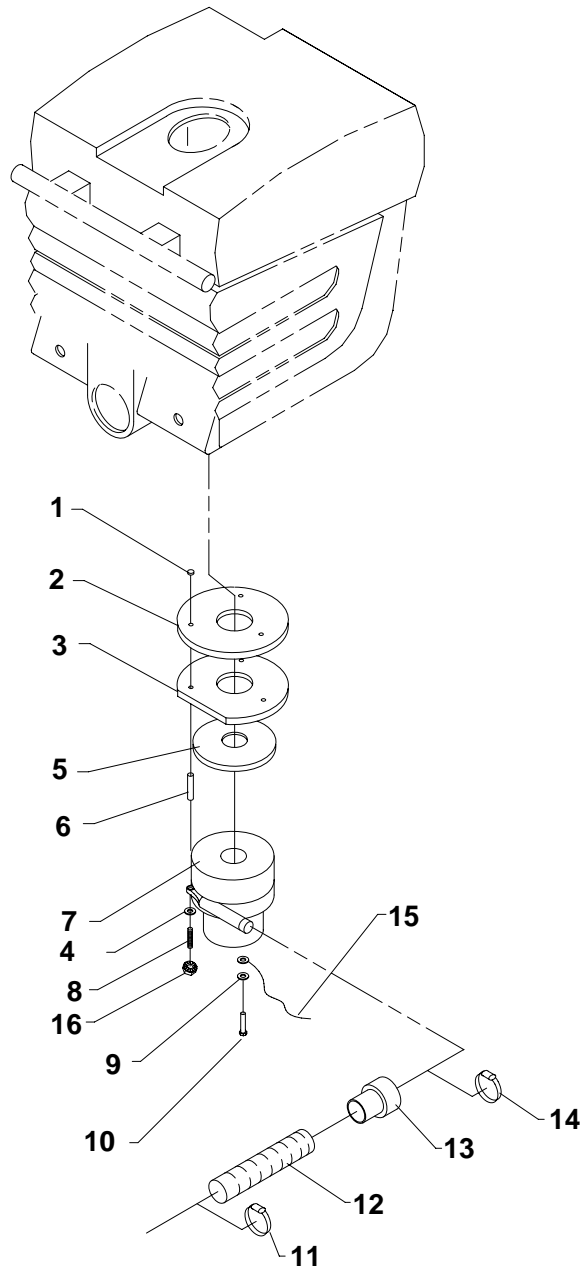

VACUUM GROUP (UPPER)

REF	PART NO.	PRV NO.	QTY	DESCRIPTION	SERIAL NO. FROM	NOTES:
1	86201510	390-26	3	SPACER NYLON 1/4 ID X 1/2 OD		
2	86237440	35168	1	GASKET, VAC BRACKET		
3	86090970	360-24	1	PLATE, VAC MTR		
4	86010630	87013	3	WASHER, 1/4 ID X 5/8 OD SS		
5	86003760	35166	1	GASKET, VAC MTR		
6	86201970	065-92	3	VAC SPACER 2 1/4 II STAGE		
7	86031620	85047	1	VAC MTR ASM, D/B RCVRY 115V 2ST		
-	86202070	360-04B	-	BRUSHES, VAC FOR 116392-00		SERVICE ONLY
-	86135320	140687	-	BRUSH SET, 120V VAC WINDSOR	1000121568	SERVICE ONLY
8	86211180	70814	3	STUD, 1/4-20 X 4.5		
9	86010640	87016	1	WASHER, #10 LOCK EXT STAR		
10	86274980	70335	1	SCR, 10-32 X 1/2 PHTR GRN/GRND		
11	86002390	20063	1	CLAMP, 1.75" WORM GEAR X .312		
12	86004190	39337	1	HOSE, 1.5 BLK VAC, 24"		
13	86234900	27508	1	CUFF, VAC HOSE BLU		
14	86002380	20046	1	CLAMP, 2.25" WORM GEAR		
15	86267480	880292	1	WIRE, 4" GRN/14 76010 X 76014		
16	86005710	57105	3	NUT, 1/4-20 HEX W/ STAR WASHER		

VACUUM GROUP (LOWER)

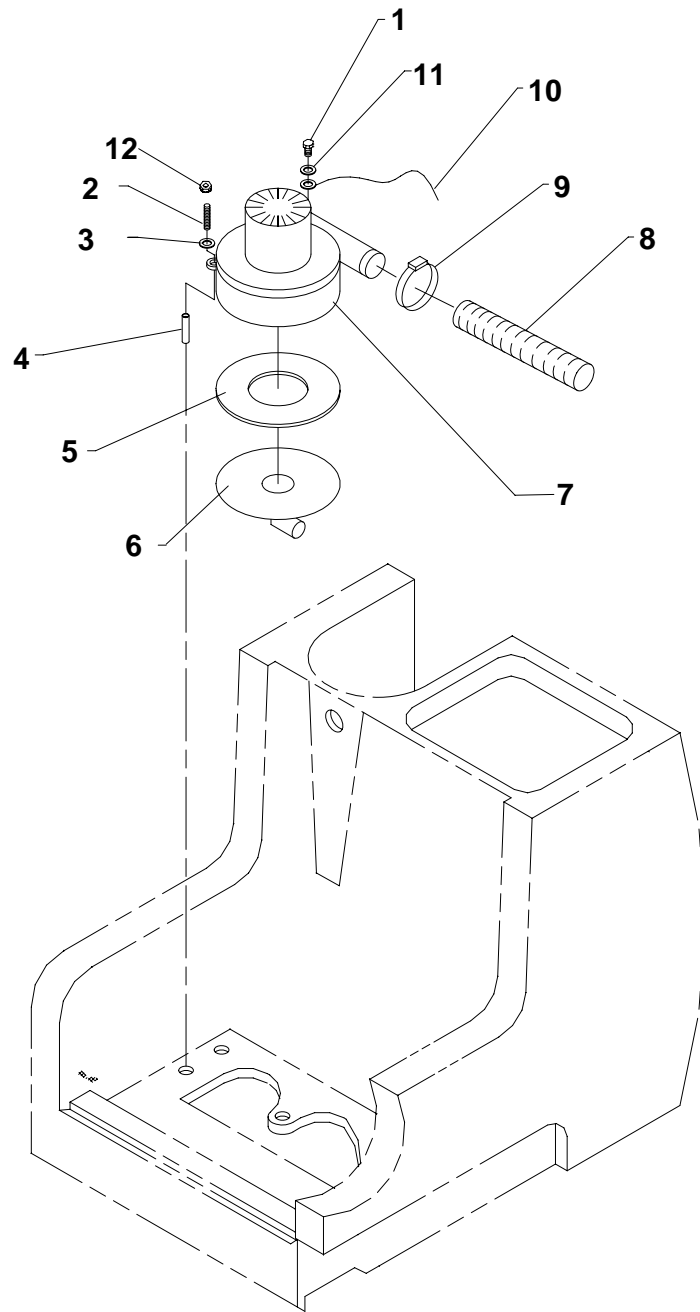

VACUUM GROUP (LOWER)

REF	PART NO.	PRV NO.	QTY	DESCRIPTION	SERIAL NO. FROM	NOTES:
1	86274980	70335	1	SCR, 10-32 X 1/2 PHTR GRN/GRND		
2	86256480	70813	3	STUD, 1/4-20 X 3.5 SS		
3	86010630	87013	3	WASHER, 1/4 ID X 5/8 OD SS		
4	86201970	065-92	3	VAC SPACER 2 1/4 II STAGE		
5	86003760	35166	1	GASKET, VAC MTR		
6	86090980	360-24A	1	PLATE ASM, VAC 90 DEG		
7	86031600	85045	1	VAC MTR ASM, D/B SLTN 115V 2ST		
-	86202070	360-04B	-	BRUSHES, VAC FOR 116392-00		SERVICE ONLY
-	86135320	140687	-	BRUSH SET, 120V VAC WINDSOR	1000121568	SERVICE ONLY
8	86282120	39582	1	HOSE, VAC EXHAUST X 9"		
9	86002380	20046	1	CLAMP, 2.25" WORM GEAR		
10	86268220	88208	1	WIRE, 21" GRN/14 76001 X 76010		
11	86010640	87016	1	WASHER, #10 LOCK EXT STAR		
12	86005710	57105	3	NUT, 1/420 HEX W/ STAR WASHER		

WIRING DIAGRAM (100 PSI)

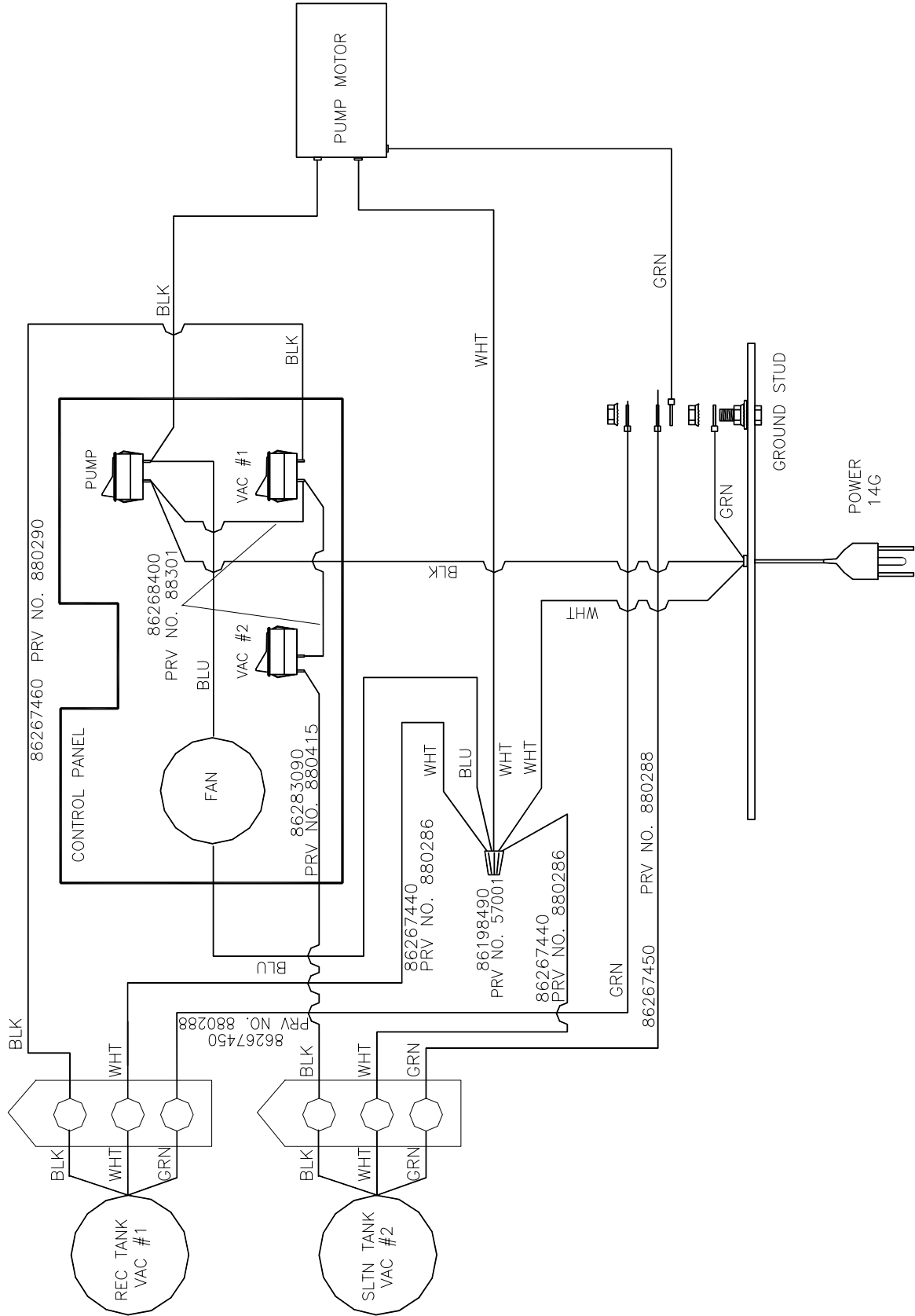

WIRING DIAGRAM (200 PSI)

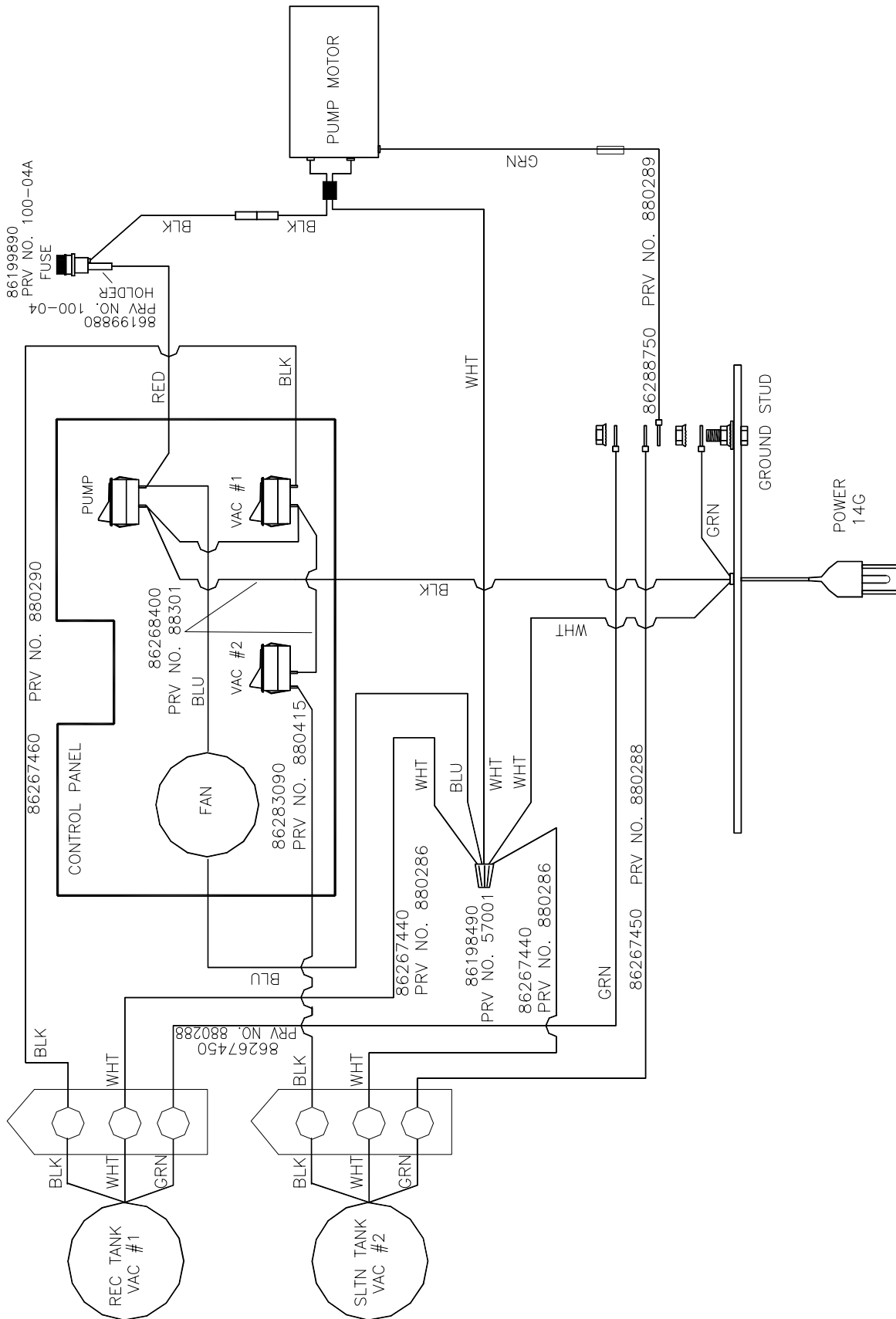

SUGGESTED SPARE PARTS

PART NO.	PART NO.	DESCRIPTION	SERIAL NO. FROM	NOTES:
86199880	100-04	FUSE HOLDER INLINE 200 PSI		
86199890	100-04A	FUSE 3 AMP 200 PSI		
86197840	31032	ELBOW, 1.5 FS X FS 45D PVC		
86256960	72142	ROCKER SWITCH 2 PRONG		WAS 330-02
86202160	320-05	VELCRO STRAPS		
86199840	090-12A	FLOAT CAGE ASSY COMPLETE SLIP		
86002620	260-64A	ACCESS COVER CLEAR 6" W/ RIM		
86251110	65219	PUMP, 115V 100PSI BYPASS W/SW (FLOJET)		100 PSI ONLY
86201210	65209	PUMP ASM, 200PSI N/H DB		200 PSI ONLY
86031600	85045	VAC MTR ASM, D/B SLTN 115V 2ST		100 PSI ONLY
86031620	85047	VAC MTR ASM, D/B RCVRY 115V ST		200 PSI ONLY
86202070	360-04B	BRUSHES, VAC FOR 116392-00		
86135320	140687	BRUSH SET, 120V VAC WINDSOR	1000121568	
86201430	250-64A	SHURFLO 100 PSI PUMP DEMAND		100 PSI ONLY

